

CRITICAL SERVICE VALVES

CORTEC is setting industry standards with our reliable critical service valve designs. CORTEC Critical Service Valves are engineered and manufactured to offer maximum safety and confidence in extreme applications where substantial amounts of abrasives, high pressures, and severe temperatures are present, and all in a lightweight, space-saving compact valve design.

CRITICAL SERVICE VALVE PRODUCT LINE

CORTEC MODEL D COMPACT BALL VALVE

The **CORTEC MODEL D** Compact Ball Valve series is designed as a standard metal seated trunnion ball valve which is the ideal solution for applications involving abrasives, high temperature, or both. Tungsten carbide-coated ball and seats provide the hard surfaces required to resist damage from abrasives and minimize wear while meeting API 6A zero leakage criteria. Stem and ball designs are robustly designed to accommodate the higher torque requirements of these metal seated valves. The **CORTEC MODEL D** series is designed with a double trunnion block support to maintain perfect alignment of the ball even at high pressures and temperatures.

CORTEC MODEL D DOUBLE BLOCK & BLEED (DBB)

The **CORTEC MODEL D** DBB design featuring spring-loaded independent upstream and downstream seats capable of providing bi-directional zero leakage from very low pressures up to 20,000 PSI.

FEATURES

- Sizes ranging from 1/2" to 24"
[Larger Nominal Sizes Available Upon Request]
- Pressures up to 20,000 PSI
- Tungsten Carbide metal-to-metal seat to ball sealing
- Valve bores can be sized to match pipe bore
- Valve models can be ordered compliant to:
 - API 6A with or without monogram
 - API 6AV1 "Sand Slurry" certified
 - Certified BSDV [Boarding Shutdown Valve]
 - API 6FA and API 607 fire-test certified
 - API 6D
 - NACE
- Third party certification available upon request
- Multiple end connections available
- Customizable to application requirements
- Manual lever/gear or power actuated
- API 6A PR2F
- 30 CFR 250 Subpart H [BSEE/SPPE] tested designs
- PSL levels 1, 2, 3, 3G, 4

Standard CORTEC MODEL D Metal Seated Trunnion DBB Ball Valve

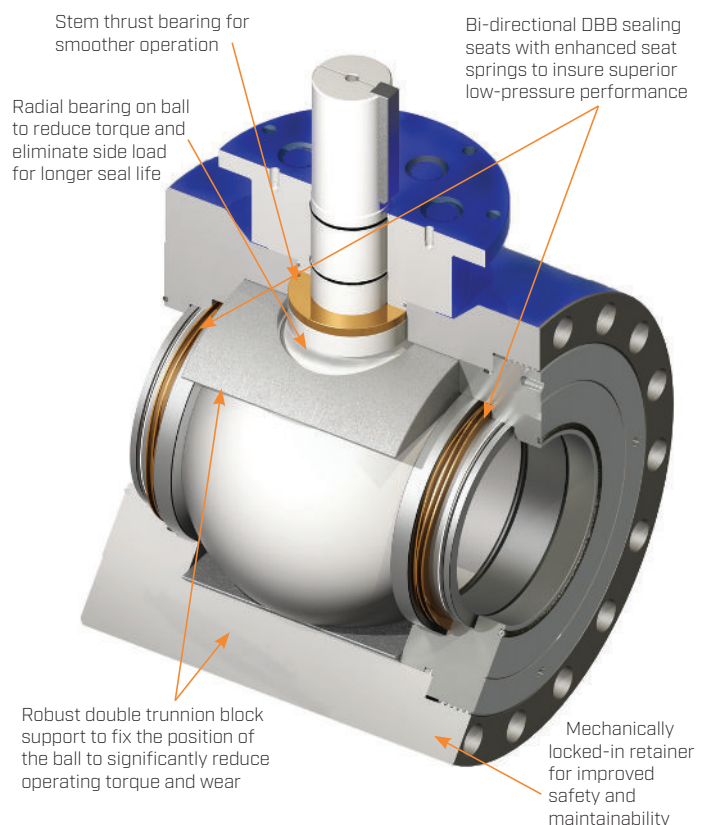

CORTEC MODEL LD COMPACT BALL VALVE

IDEAL USES: Boarding Shutdown Valves (BSDV), Gas Lift Shutdown Valves (GLSDV), or Subsea Safety Valves (SSV)

For valves used in critical applications such as BSDV, GLSDV, or SSV, CORTEC developed the **MODEL LD** Compact Ball Valve series. This series of metal seated valves are designed to function in the most extreme circumstances, including temperature, pressure, flow rates with abrasives and other adverse conditions.

The **CORTEC MODEL LDs** are manufactured using materials and sealing elements that are designed to last for the life of the well. For this long-term operability, attention is given to all sealing areas, not just the bore sealing mechanism (seat-to-ball seal). This series uses specially designed spring energized lip seals on all primary sealing elements. Special attention is given to the design of these lip seals to ensure reliable sealing from very low up to full-rated working pressure, and additionally, the materials used in sealing gland areas are selected for continued dependability. CORTEC's designs include provisions for Inconel 625 overlays, in accordance with API 6A, to greatly improve reliability and longevity in all areas of the valve.

Please consult with your CORTEC representative for additional information.

Standard CORTEC MODEL LD Metal Seated Trunnion DBB Ball Valve

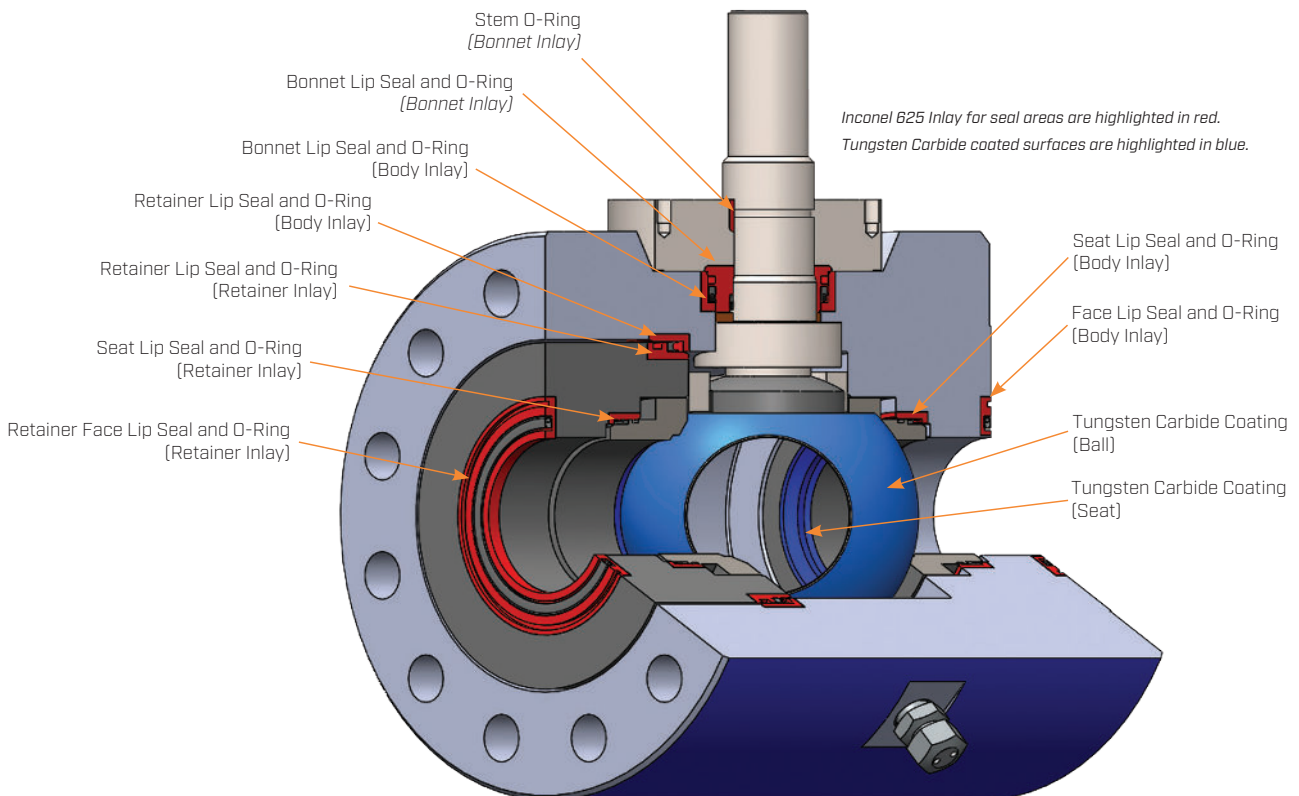

Contact our **Critical Service Valve Sales Team** today for more info at **225-421-3300** or **sales@uscortec.com**.

No other flow control manufacturer strives to exceed their customers' needs and expectations more than CORTEC.



AMERICAN MADE. SUPERIOR GRADE.

uscortec.com

CORTEC proudly operates two US based manufacturing facilities in Louisiana.

V004_CSV_v.2.02