

COMPACT VALVES

CORTEC Compact Ball Valves are designed for high pressure isolation and offer considerable space and weight savings when compared to traditional ANSI and API class valves. CORTEC Compact Ball Valves are available in a range of bore sizes and working pressures.

CORTEC Compact Ball Valves are designed to provide reliable long-term service life and ease of maintenance. Unique side entry body and associated end connections make valve removal from the line easy, making repairs simple. Disassembly, in most cases, is accomplished without the need for special tools.

Design Features and Benefits

- Valve models are available in size range of 1/2" thru 24" nominal and are bore sized to API bore sizes, common piping schedules or project requirements. (Larger Nominal Sizes Available Upon Request)
- Pressures to 20,000 PSI
- Provide reliable long-term service life and are field friendly for serviceability.
- Virtually any size and type of end connection is available (buttweld, threaded union, hub and crossovers to both ANSI and API flanges).
- Ball valves are offered with a variety of seating material options such as Celcon, PEEK or Tungsten Carbide metal-to-metal.
- Fire-safe designs have been independently qualified to API 6FA.
- Valve models can be ordered compliant to:
 - API 6A with or without monogram
 - API 6 AV1 "Sand Slurry"
 - API 6D
 - NACE
- Third party certification available upon request
- Ball valves are a quarter turn design and can be supplied as either manual lever / gear or actuated.
- API 6A PR2F
- PSL levels 1, 2, 3, 3G, 4

Why compact?

Less space

Less weight

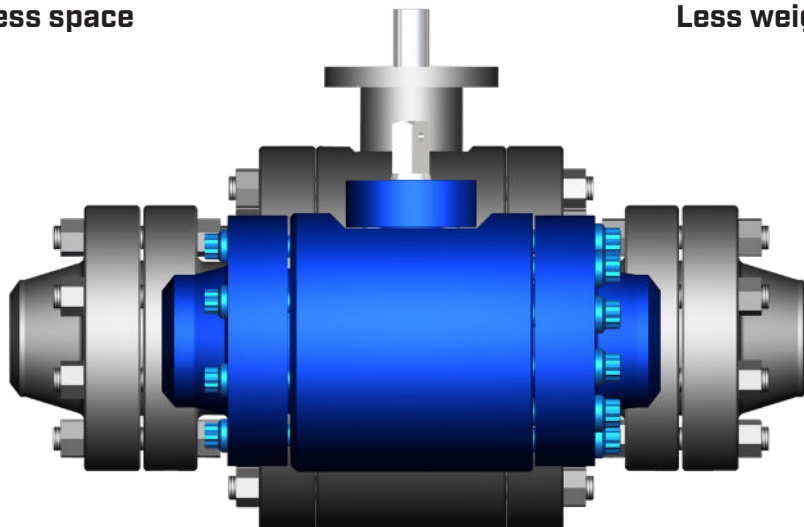

CORTEC

AMERICAN MADE. SUPERIOR GRADE.

uscortec.com

CORTEC proudly operates two US based manufacturing facilities in Louisiana.

V003_CBV_v2.0

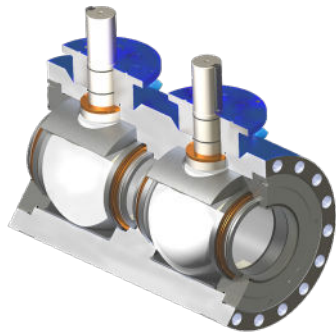
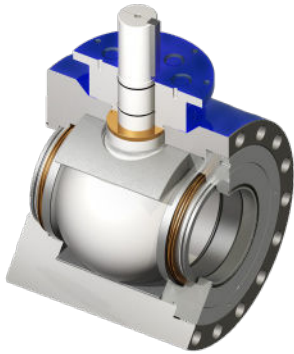

CORTEC Model “D” Compact Trunnion Ball Valve

The CORTEC Model “D” Series Ball Valve is a double trunnion design. The ball is held firmly in place by two large trunnion blocks, allowing only rotational movement. With the ball always perfectly aligned, independent spring-loaded upstream and downstream seats are always in contact with the ball, which provides an effective tight seal even at very low pressures. The Double Trunnion design permits ease of operation and significantly reduces torque. Our use of robust double trunnions and spring-loaded seats affords the most reliable configuration. The “D” Series Ball Valve can be supplied with polymeric or metal seats. Every valve is DBB (Double Block & Bleed) and is equipped with stainless steel vent fitting that allows the body cavity to be easily bled.

Design Features and Benefits

- Size ranging from 1/2” to 24” (Larger Nominal Sizes Available Upon Request)
- Pressures to 20,000 PSI
- Polymeric or Tungsten Carbide metal-to-metal sealing
- Designs featuring primary lip seal technology available upon request
- Subsea models available
- API 6AV1 “Sand Slurry” Certified design option
- API 6FA Certified fire-tested designs
- Customizable to application requirements
- Valve bore can be sized to match pipe bore
- Multiple end connections available
- Manual lever / gear or actuated

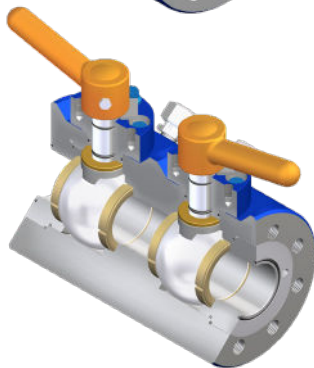
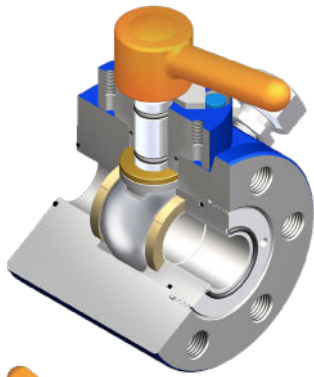

CORTEC Model “B/BC” Compact Floating Ball Valve

The CORTEC Model “B/BC” Series Ball Valve is a floating ball and dual floating seat design. The floating ball is preloaded between the seats during assembly and moves incrementally tighter against the seats as line pressure increases. It will provide a reliable positive shutoff in either flow direction. The removable bonnet design allows for field replacement of the stem seal without removing the valve from the pipe. A stainless steel body injection fitting is a standard feature for providing routine lubrication of the body cavity, which reduces the operating torque and extends the service life. This injection fitting can also be used for the injection of emergency sealant. The “B/BC” class valve is also available with throttle balls for throttling under high differential pressures.

Design Features and Benefits

- Sizes ranging from 1” thru 3”
- Pressures to 15,000 PSI
- Polymeric seating material options
- Subsea models available
- API 6FA Certified fire-tested designs
- Customizable to application requirements
- Valve bore can be sized to match pipe bore
- Multiple end connections available
- Manual lever / gear or actuated

Contact our expert **Sales Team** today for more info at **225-421-3300** or **sales@uscortec.com**

No other manufacturer strives to exceed their customers' needs and expectations more than CORTEC.



CORTEC

AMERICAN MADE. SUPERIOR GRADE.

uscortec.com

CORTEC proudly operates two US based manufacturing facilities in Louisiana.

V003_CBV_v2.0