

PRODUCTION CHOKES

What should I consider before selecting a choke?

- Working pressure and temperature
- Inlet and outlet connections: size, type, etc.
- Nominal body size
- Trim type: tapered needle, cage and sleeve, rotating disc, positive bean, etc.
- Means of operation: manual hand wheel or remotely actuated
- Service conditions: corrosive, abrasive, sour
- Flow media and specifications: oil, gas, water, specific gravity, etc.
- Flow rates: minimum, normal and maximum
- Design and quality requirements: API, ANSI, etc.

Orifice Sizing and Selection

Probably the most misunderstood aspect of buying a choke is proper orifice sizing and trim style selection. It is critical to the proper performance, function, service life and operator satisfaction. It is imperative that the choke and its associated components are properly selected based on the intended application. A choke that is equipped with the optimal trim size and style will assure maximum service life, flowing performance and minimize down time.

CORTEC employs flow control sizing software based on the Instrument Society of America rules, as well as years of experience and field confirmation. During the inquiry and sales process, we encourage the customer to provide flow data and allow us to perform flow calculations. These calculations will aid in selection of the correct orifice size and style and will allow us to make informed product recommendations. CORTEC can assist this process by providing a data input form for the customer to complete.

Choke Bolting Dimensions

CORTEC chokes are manufactured to standard inlet and outlet dimensions. Our manufacturing process allows us the versatility to supply chokes to custom inlet and outlet dimensions with a wide variety of common and custom connections. This allows you to replace your existing choke without costly piping changes in the field.

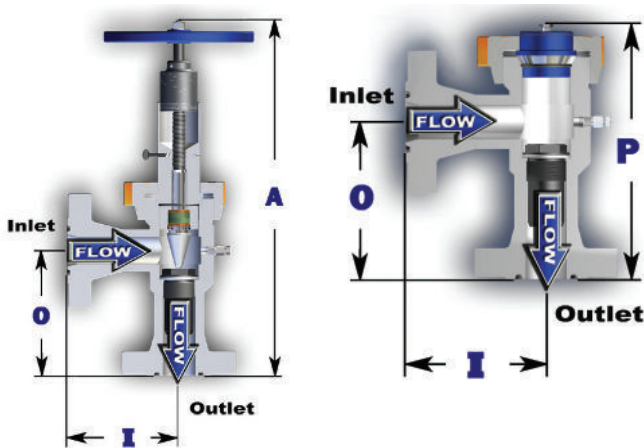

Type Dimension Description

- I** Inlet dimensions are from the centerline of the outlet to the face of the inlet flange.
- O** Outlet dimensions are from the centerline of the inlet to the face of the outlet flange.
- P** Overall length of the positive model of the choke.
- A** Overall length of the adjustable model of the choke in the fully closed position.

TRIM OPTIONS

Proper orifice sizing and trim style selection is critical to proper performance, function, service life and operator satisfaction.

Cage and Sleeve Trim

CORTEC MODEL – CC

- Low Pressure Recovery Characteristics
- Erosion resistant prolonging trim life
- Pressure balanced to reduce torque
- For severe service applications including abrasive service
- ANSI Seat Class IV 6V
- Firesafe

Rotary Disc Trim

CORTEC MODEL – RM

- High range ability requirements in severe erosive applications

Needle and Seat Trim

CORTEC MODELS – NH, NC, NCH, NG8746, and NJWA

- Fully adjustable as flow rates and pressures fluctuate
- Easy to replace in the field
- Parts are interchangeable with popular models
- Suitable for low to medium pressure drops, less severe service

Positive Choke Bean

CORTEC MODELS – PH, PC, PCH, PG8746 and PPC

- The simplest, most inexpensive configuration
- Engineered for heavy duty, maintenance free performance
- Parts are interchangeable with popular models
- Installation, parts replacement, and other field work are simple



CORTEC

AMERICAN MADE. SUPERIOR GRADE.

uscortec.com

CORTEC proudly operates two US based manufacturing facilities in Louisiana.

CO11_PC_v2.0

Choke Configurations

CORTEC uses only the highest quality materials to manufacture some of the most innovative yet easy to use choke designs known today. Each design is adaptable to meet changing well flow conditions over the life in the field.

Configurations:

- Positive Bean Configuration
- Needle and Seat Configuration
- Cage and Sleeve Trim Configuration
- Actuated (Electric, Pneumatic, and Hydraulic)

Specifications:

- Orifice sizes ranging from 1/4" to 5"
- API 2,000–20,000 PSI CWP
- ANSI Class 600–2,500
- Severe Service Applications
- PSL 1, 2, 3, 3G, and 4

Quality Assurance:

- API Specification Q1
- ISO 9001
- Built to meet or exceed API 6A Specifications
- Customer Specified Preferences

Cap Bonnet Options

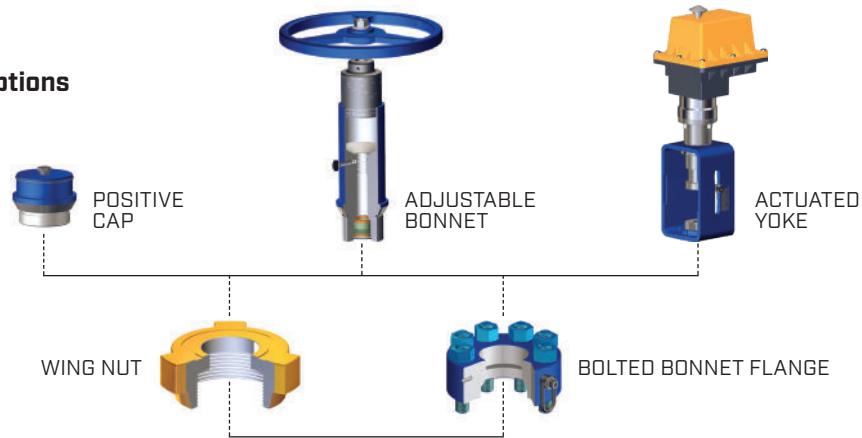

Bonnet Seal Options



Trim Options

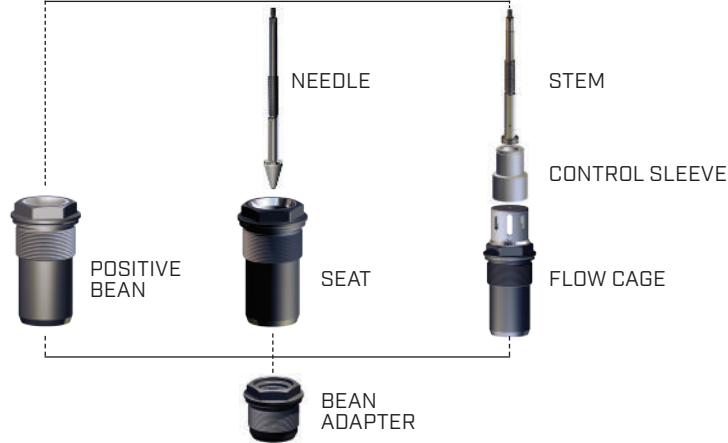

Model "C" or "H" Body



Contact our expert **Sales Team** today for more info at **985-223-1966** or sales@uscortec.com

No other manufacturer strives to exceed their customers' needs and expectations more than CORTEC.



AMERICAN MADE. SUPERIOR GRADE.

CORTEC proudly operates two US based manufacturing facilities in Louisiana.

uscortec.com

C011_PC_v.2.0